



Main

Range of product	Altivar Easy 310
Product or component type	Variable speed drive
Product specific application	Simple machine
Assembly style	With heat sink
Device short name	ATV310
Network number of phases	Three phase
[Us] rated supply voltage	380...460 V (- 15...10 %)
Motor power kW	0.37 kW
Motor power hp	0.5 hp

Complementary

Product destination	Asynchronous motors
Quantity per set	Set of 1
EMC filter	Without EMC filter
Supply frequency	50/60 Hz +/- 5 %
Communication port protocol	Modbus
Type of connector	RJ45 for Modbus on front face
Physical interface	2-wire RS 485 for Modbus
Transmission frame	RTU for Modbus
Transmission rate	38400 bit/s 19200 bit/s 9600 bit/s 4800 bit/s
Number of addresses	1...247 addresses for Modbus
Communication service	Read device identification (43) Read/Write multiple registers (23), messaging: 4/4 words Write multiple registers (16), messaging: 27 words Write single register (06), messaging: 29 words Read holding registers (03), messaging: 29 words
Line current	1.8 A
Apparent power	1.4 kVA
Prospective line I _{sc}	<= 5 kA
Continuous output current	1.5 A at 4 kHz
Maximum transient current	2.3 A for 60 s
Power dissipation in W	19.63 W at I _n
Speed drive output frequency	0.5...400 Hz
Nominal switching frequency	4 kHz
Switching frequency	2...12 kHz (adjustable)
Speed range	1...20
Transient overtorque	170...200 % of nominal motor torque depending on drive rating and type of motor
Braking torque	Up to 70 % of nominal motor torque without braking resistor Up to 150 % of nominal motor torque with braking resistor at high inertia
Asynchronous motor control profile	Energy saving ratio Quadratic voltage/frequency ratio Sensorless flux vector control
Motor slip compensation	Adjustable Preset in factory
Output voltage	380...460 V three phase

The information provided in this documentation contains general descriptions and/or technical characteristics of the performance of the products contained herein. This documentation is not intended as a substitute for and is not to be used for determining suitability or reliability of these products for specific user applications. It is the duty of any such user or integrator to perform the appropriate and complete risk analysis, evaluation and testing of the products with respect to the relevant specific application or use thereof. Neither Schneider Electric Industries SAS nor any of its affiliates or subsidiaries shall be responsible or liable for misuse of the information contained herein.

Electrical connection	1.5...2.5 mm ² at terminal L1, L2, L3, PA/+, PB, U, V, W
Tightening torque	0.8...1 N.m
Insulation	Electrical between power and control
Supply	Internal supply for logic inputs : 24 V (20.4...28.8 V) DC 100 mA with overload and short-circuit protection Internal supply for reference potentiometer : 5 V (4.75...5.25 V) DC 10 mA with overload and short-circuit protection
Analogue input number	1
Analogue input type	Configurable voltage (AI1) 0...5 V, impedance 30 kOhm Configurable voltage (AI1) 0...10 V, impedance 30 kOhm Configurable current (AI1) 0...20 mA, impedance 250 Ohm
Discrete input number	4
Discrete input type	24 V (18...30 V) programmable, at LI1...LI4 terminal(s)
Discrete input logic	Positive logic (source), 0...< 5 V (state 0), > 11 V (state 1) Negative logic (sink), > 16 V (state 0), < 10 V (state 1), input impedance 3.5 kOhm
Sampling duration	< 20 ms, tolerance +/- 1 ms for logic input < 10 ms for analogue input
Linearity error	+/- 0.3 % of maximum value for analogue input
Analogue output number	1
Analogue output type	AO1 software-configurable current : 0...20 mA, impedance: 800 Ohm, resolution 8 bits AO1 software-configurable voltage : 0...10 V, impedance: 470 Ohm, resolution 8 bits
Discrete output number	2
Discrete output type	(R1A, R1B, R1C) protected relay output 1 C/O (LO+, LO-) logic output
Minimum switching current	5 mA at 24 V DC for logic relay
Maximum switching current	4 A at 30 V DC on resistive load (cos phi = 1 L/R = 0 ms) for logic relay 3 A at 250 V AC on resistive load (cos phi = 1 L/R = 0 ms) for logic relay 2 A at 30 V DC on inductive load (cos phi = 0.4 L/R = 7 ms) for logic relay 2 A at 250 V AC on inductive load (cos phi = 0.4 L/R = 7 ms) for logic relay
Acceleration and deceleration ramps	S U Linear from 0...999.9 s
Braking to standstill	By DC injection, 0.1...30 s
Protection type	Thermal motor protection via the drive by continuous calculation of I ² t Against input phase loss in three-phase Short-circuit between motor phases Overheating protection Overcurrent between output phases and earth Line supply undervoltage Line supply overvoltage
Frequency resolution	0.1 Hz for display unit Converter A/D, 10 bits for analog input
Time constant	20 ms, tolerance +/- 1 ms for reference change
Operating position	Vertical +/- 10 degree
Height	130 mm
Width	72 mm
Depth	143 mm
Product weight	0.7 kg

Environment

Electromagnetic compatibility	Surge immunity test (test level: level 3) conforming to EN/IEC 61000-4-5 Voltage dips and interruptions immunity test conforming to EN/IEC 61000-4-11 Radiated radio-frequency electromagnetic field immunity test (test level: level 3) conforming to EN/IEC 61000-4-3 Immunity to conducted disturbances (test level: level 3) conforming to EN/IEC 61000-4-6 Electrostatic discharge immunity test (test level: level 3) conforming to EN/IEC 61000-4-2 Electrical fast transient/burst immunity test (test level: level 4) conforming to EN/IEC 61000-4-4
Standards	EN/IEC 61800-3 EN/IEC 61800-5-1
IP degree of protection	IP41 on top IP20 without blanking plate on upper part
Pollution degree	2 conforming to EN/IEC 61800-5-1
Environmental characteristic	Chemical pollution resistance class 3C3 conforming to EN/IEC 60721-3-3 Dust pollution resistance class 3S2 conforming to EN/IEC 60721-3-3
Shock resistance	15 gn (duration = 11 ms) conforming to EN/IEC 60068-2-27
Relative humidity	5...95 % (without dripping water) conforming to IEC 60068-2-3 5...95 % (without condensation) conforming to IEC 60068-2-3
Ambient air temperature for storage	-25...70 °C
Ambient air temperature for operation	55...60 °C protective cover from the top of the drive removed with current derating 2.2 % per °C -10...55 °C without derating
Operating altitude	<= 1000 m without derating

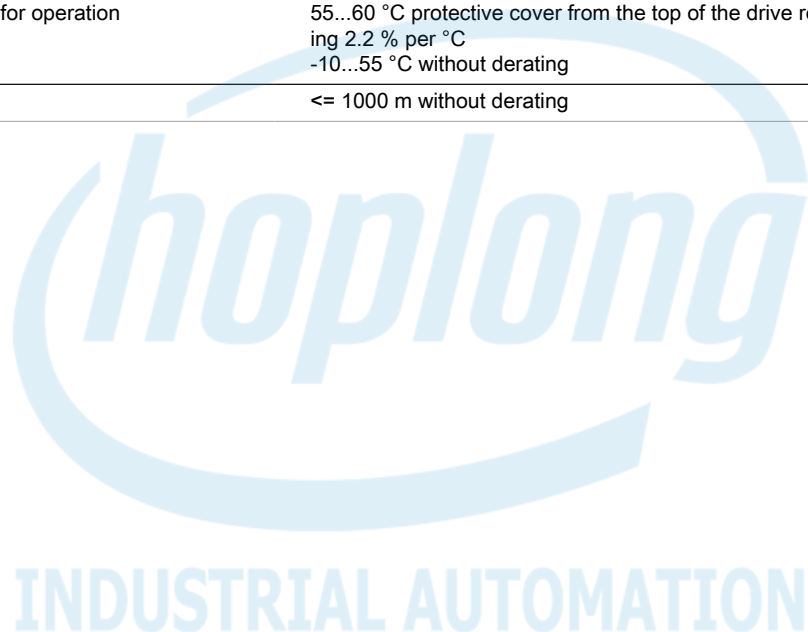

Dimensions

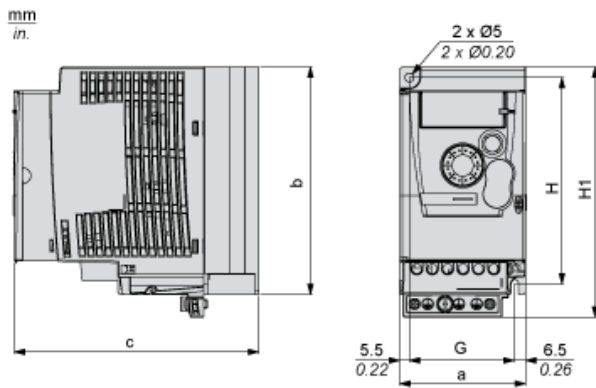

Dimensions in mm

a	b	c	G	H	H1	Ø	For screws
72	130	130	60	118	143	5	M4

Dimensions in in.

a	b	c	G	H	H1	Ø	For screws
2.83	5.12	5.12	2.36	4.65	5.63	0.20	M4

hoplong
INDUSTRIAL AUTOMATION

Mounting Recommendations

Clearance

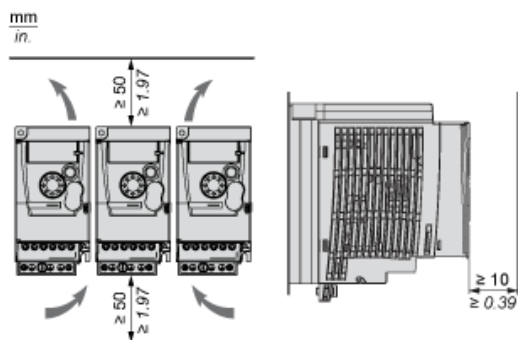

Mounting Types

Mounting Type A

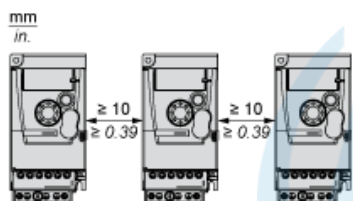

Mounting Type B

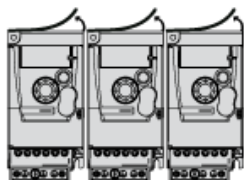

Remove the protective cover from the top of the drive.

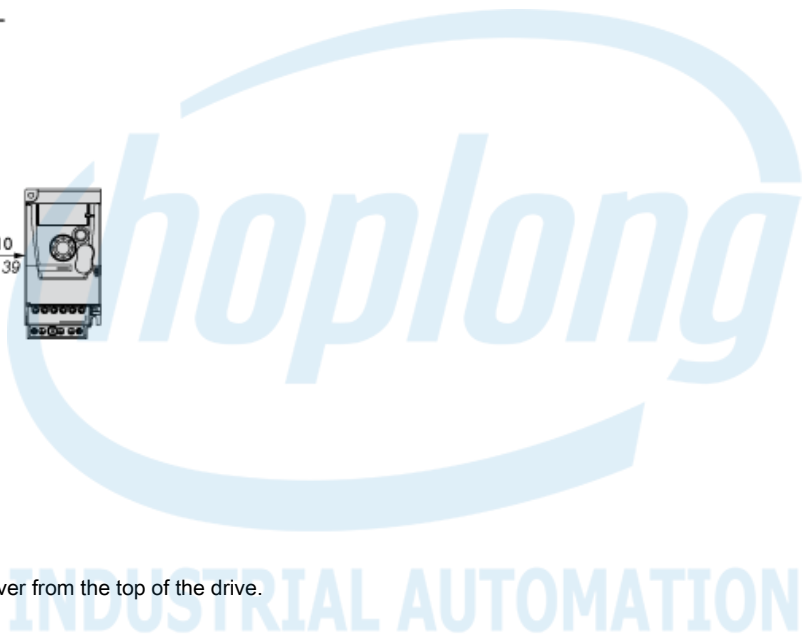

Three-Phase Power Supply Wiring Diagram

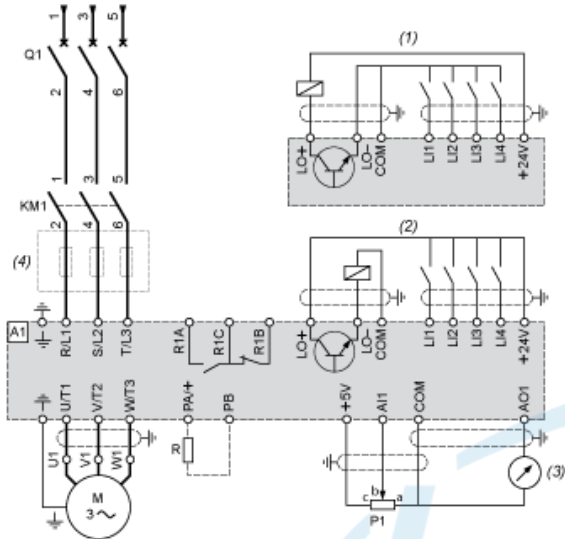

- A1 : Drive
- KM1 : Contactor (only if a control circuit is needed)
- P1 : 2.2 kΩ reference potentiometer. This can be replaced by a 10 kΩ potentiometer (maximum).
- Q1 : Circuit breaker
- R : Braking resistor (optional)
- (1) Negative logic (Sink)
- (2) Positive logic (Source) (factory set configuration)
- (3) 0...10 V or 0...20 mA
- (4) Line choke three-phase (optional)

INDUSTRIAL AUTOMATION